

# The Power-Oriented Graphs Technique: system modeling and basic properties

Roberto Zanasi

DII, University of Modena e Reggio Emilia, Via Vignolese 905, 41100, Modena, Italy,  
e-mail: roberto.zanasi@unimore.it

**Abstract**—In this paper the Power-Oriented Graphs (POG) technique is introduced and its basic graphical properties are compared with those of the Bond Graph (BG) technique. The two techniques are based on the same concepts, are equivalent from a mathematical point of view and use two different graphical representations for modeling physical systems. The BG schemes are quite compact and more flexible in the exact description of all the power connections within the system. The POG schemes are easier to use for beginners and use vectorial compact forms when the system complexity increases. The paper ends describing some “dissipative” properties of the POG state space model.

## I. INTRODUCTION

The Bond Graphs (BG) [1], [2], the Power-Oriented Graphs (POG) [3], [4] and the Energetic Macroscopic Representation (EMR) [5], [6] are graphical modeling techniques which use an *energetic approach* for modeling physical systems. The basic concepts of the energetic approach were firstly introduced by H.M. Paynter in the early-sixties together with the basic “bond” graphical notation, see [1]. In the last fifty years the BG technique has been deeply studied, largely developed and applied to a very large number of different physical systems, see [2] and the inside references. The key element of the BG is the use of a graphical notation which is quite compact and flexible in representing the power connections, but is not easy to use for beginners and this aspect has somehow “limited” the wide-world diffusion of this good technique. The POG technique, introduced in 1991, is based on the same energetic approach of the BG technique, but it uses a different graphical notation (i.e. simple block diagrams) for modeling the physical systems. The POG block schemes are easy to use, easy to understand and can be directly implemented in Simulink. For these reasons the POG technique can be a useful tool for promoting the use of the energetic approach also between beginners and young researchers. The EMR is a graphical technique introduced in 2000, see [5], which clearly shows the power coupling among elements and the energy flux through the system without showing the mathematical details of the model. This technique is mainly focused on giving rules for the automatic deduction of effective control schemes that can be implemented in real-time. In this paper the main concepts of POG modeling are introduced and compared with those of the BG technique. This comparison clearly shows that these two techniques use two different graphical representations, but they are essentially “equivalent” from a mathematical point of view. Examples of application of the POG graphical technique can be found in [3], [4], [7], [8] and the inside references.

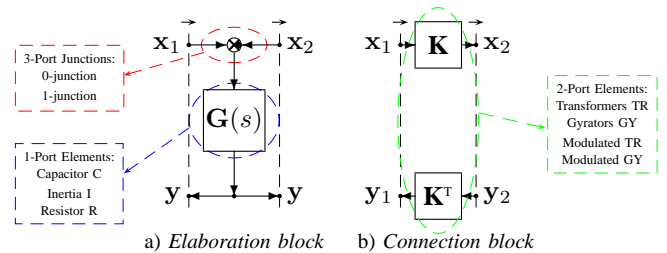

Figure 1. POG basic blocks: *elaboration block* and *connection block*.

## II. THE POWER-ORIENTED GRAPHS TECHNIQUE

The BG, POG and EMR graphical techniques use the *Power* and *Energy* variables as basic concepts for modeling physical systems. This *energetic approach* is useful for modeling because all the dissipative physical systems are characterized by these properties: 1) a system always *stores and/or dissipates energy*; 2) the dynamic model of a physical system describes *how the energy moves* within the system, 3) the energy moves from point to point only by means of two *power variables*.

**The two POG basic blocks:** the POG technique uses only two basic blocks for modeling the physical systems, see Fig. 1:

a) the **elaboration block** (e.b.) is used for modeling all the physical elements that store and/or dissipate energy (i.e. springs, masses, dampers, capacities, inductances, resistances, etc.). With this block it is possible to model all the 1-port elements (capacitors C, inertias I and resistor R) used in the BG technique. The summation element at the top of the block is suitable for modeling all the 3-port connection elements (0-junction and 1-junction) of the BG technique. The black spot within the summation element represents, when is present, a minus sign that multiplies the entering variable. The e.b. can be scalar or vectorial and for linear systems matrix  $G(s)$  is always a square matrix of positive real transfer functions.

b) the **connection block** (c.b.) is used for modeling all the physical elements that “transform the power without losses” (i.e. *neutral elements* such as gear reductions, transformers, etc.). This block models all the 2-port elements (transformers TR, gytrators GY, modulated transformers MTR and modulated gytrators MGY) of the BG technique. Also the c.b. can be scalar or vectorial. In the vectorial case matrix  $K$  can also be rectangular, time varying or function of other state variables.

**Power sections:** the dashed lines in Fig. 1 represent the power sections which connect the two POG basic blocks with the external world. There are no restrictions on the choice

of the vectors  $\mathbf{x}$  and  $\mathbf{y}$  involved in each dashed line except the fact that the inner product  $\langle \mathbf{x}, \mathbf{y} \rangle = \mathbf{x}^T \mathbf{y}$  must have the physical meaning of *power flowing through the section*. The basic concepts of how to model physical systems using power variables are introduced in the following section. Moreover the POG *elaboration* and *connection blocks* will be described in details and compared with the corresponding symbols used in the Bond Graphs technique.

### III. SYSTEM MODELING USING POWER VARIABLES

**Energetic domains:** the main energetic domains encountered in modeling physical systems are: electrical, mechanical (translational and rotational) and hydraulic. Each energetic domain has its own couple of power variables, see Fig. 2.

**Power variables:** they can be divided in two groups:

1) the “*across-variables*” (i.e. voltage  $V_p$ , velocity  $\dot{x}_p$ , angular velocity  $\omega_p$  and pressure  $P_p$ ) which are defined “*between two points  $P$  and  $0$* ” of the space:

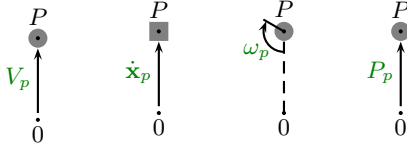

2) The “*trough-variables*” (i.e. current  $I_p$ , force  $F_p$ , torque  $\tau_p$  and volume flow rate  $Q_p$ ) which are defined “*in each point  $P$* ” of the space:

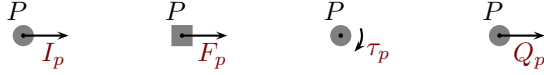

**Dynamic structure of the Energetic Domains:** each energetic domains is characterized only by 3 different types of physical elements:

- 2 *dynamic elements*  $D_e$  and  $D_f$  which store the energy (i.e. capacitors, inductors, masses, springs, etc.);
- 1 *static element*  $R$  which dissipates (or generates) the energy (i.e. resistors, frictions, etc.);

The system dynamics can be described using 4 variables:

- 2 *energy variables*  $q_e$  and  $q_f$  which define *how much energy is stored* within the *dynamic elements*;
- 2 *power variables*  $v_e$  and  $v_f$  which describe *how the energy moves* within the system.

The dynamic/static elements and the energy/power variables for the considered Energetic Domains are shown in Fig. 2.

**Mathematical structure of the physical elements:** the *dynamic element*  $D_e$  is characterized by:

- 1) an internal *energy variable*  $q_e(t)$ ;
- 2) a *trough-variable*  $v_f(t)$  as input variable;
- 3) an *across-variable*  $v_e(t)$  as output variable;
- 4) a *constitutive relation*  $q_e = \Phi_e(v_e)$  which links the internal variable  $q_e(t)$  to the output variable  $v_e(t)$ ;
- 5) a *differential equation*  $\dot{q}_e(t) = v_f(t)$  which links the internal variable  $q_e(t)$  to the input variable  $v_f(t)$ ;

The energy  $E_e$  stored in the *dynamic element*  $D_e$  is function only of the internal *energy variable*  $q_e$ :

$$E_e = \int_0^t v_e(t) v_f(t) dt = \int_0^{q_e} \Phi_e^{-1}(q_e) dq_e = E_e(q_e).$$

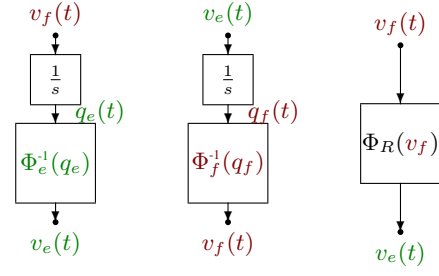

Figure 3. Structure of *Dynamic elements*  $D_e$  and  $D_f$  and *Static element*  $R$ .

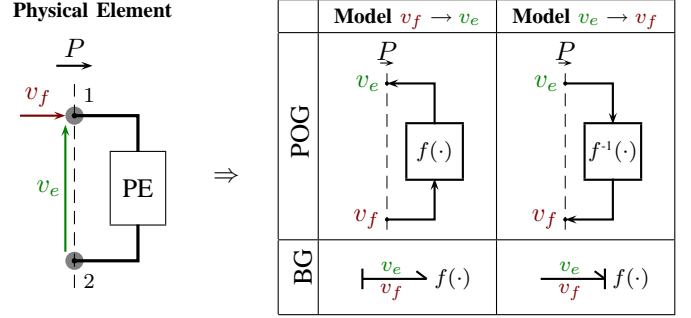

Figure 4. The two POG block diagrams used for graphically describe the mathematical model of the physical element PE. Two different orientations correspond (depending on PE) to the integral and derivative causality models.

The *dynamic element*  $D_f$  has a structure that is “*dual*” respect to the structure of *dynamic element*  $D_e$ , see Fig. 3. The dual structure can be easily obtained performing the following substitutions:  $q_e(t) \rightarrow q_f(t)$ ,  $v_f(t) \leftrightarrow v_e(t)$  and  $\Phi_e(v_e) \rightarrow \Phi_f(v_f)$ . The *static element*  $R$  is completely characterized by a static function  $v_e = \Phi_R(v_f)$  which links the input variable  $v_f$  to the output variable  $v_e$ , see Fig. 3.

**Conventions on the positive power flows:** the physical systems are composed by basic Physical Elements (PE) (i.e. *dynamic elements*  $D_e$  and  $D_f$  or *static element*  $R$ ) which interact with the external world by means of two terminals (denoted 1 and 2 in Fig. 4), each one characterized by two power variables  $(v_{e1}, v_{f1})$  and  $(v_{e2}, v_{f2})$ . Choosing  $v_e = v_{e1} - v_{e2}$  and  $v_f = v_{f1} = v_{f2}$  as new power variables, it follows that the power interaction of the PE with the external world can be described using only the power section  $P$  shown in the left part of Fig. 4. The value of the power  $P$  flowing through the section is the product of the two power variables  $v_e(t)$  and  $v_f(t)$ :  $P(t) = v_e(t) v_f(t)$ . The sign and the direction of power  $P(t)$  depend on the sign and the reference positive direction chosen for the variables  $v_e(t)$  and  $v_f(t)$ . The POG conventions used for a correct definition of the sign of the power  $P$  flowing through a physical section  $A-B$  are shown Fig. 5. The POG technique uses a small arrow “ $\rightarrow$ ” drawn in the vicinity of power section (i.e. the dashed line) to indicate (when it is necessary) the positive direction of power  $P$ . In Fig. 5 are also reported the graphical symbols used by BG technique for describing the same conventions.

**Models with integral and derivative causality:** the dynamic model of each physical element PE can always be graphically

|             | Electrical                    | Mech. Tras.      | Mech. Rot.                 | Hydraulic            |
|-------------|-------------------------------|------------------|----------------------------|----------------------|
| Across-Var. | $\mathcal{D}_e$ $C$ Capacitor | $M$ Mass         | $J$ Inertia                | $C_I$ Hyd. Capacitor |
|             | $q_e$ $Q$ Charge              | $p$ Momentum     | $\tilde{p}$ Ang. Momentum  | $V$ Volume           |
|             | $v_e$ $V$ Voltage             | $v$ Velocity     | $\omega$ Ang. Velocity     | $P$ Pressure         |
| Trough-Var. | $\mathcal{D}_f$ $L$ Inductor  | $E$ Spring       | $E$ Spring                 | $L_I$ Hyd. Inductor  |
|             | $q_f$ $\phi$ Flux             | $x$ Displacement | $\theta$ Ang. Displacement | $\phi_I$ Hyd. Flux   |
|             | $v_f$ $I$ Current             | $F$ Force        | $\tau$ Torque              | $Q$ Volume flow rate |
|             | $\mathcal{R}$ $R$ Resistor    | $b$ Friction     | $b$ Ang. Friction          | $R_I$ Hyd. Resistor  |

Figure 2. The main energetic domains: the physical elements  $\mathcal{D}_e$ ,  $\mathcal{D}_f$  and  $\mathcal{R}$ ; the energy variables  $q_e$ ,  $q_f$ ; the power variables  $v_e$ ,  $v_f$ .

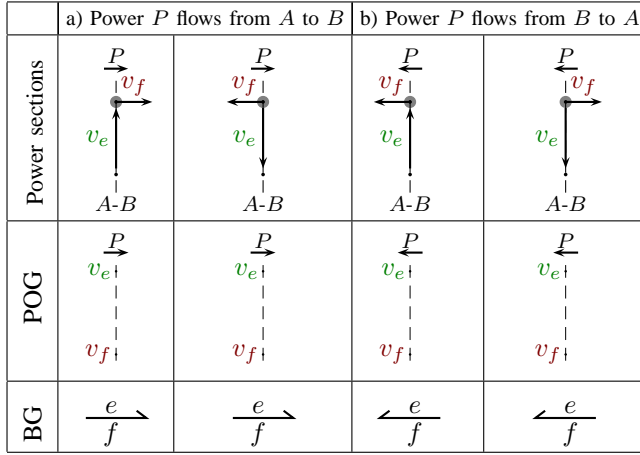

Figure 5. Conventions for the correct definition of the sign of the power  $P$ .

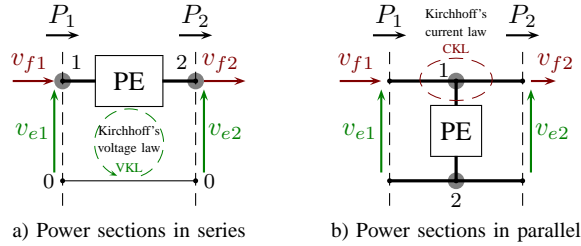

Figure 6. Two different power connections of the PE with the external world.

described by using the block diagrams shown in the right part of Fig. 4. These diagrams correspond to the two possible orientations of the dynamic model of the PE:  $v_f$  as input and  $v_e$  as output,  $v_e$  as input and  $v_f$  as output. The function  $f(\cdot)$  in Fig. 4 symbolically represents one of the dynamic or static models shown in Fig. 3. If the PE is a static element, i.e. if  $PE = \mathcal{R}$ , both diagrams are suitable for describing the mathematical model of the element. If the PE is a dynamic element, i.e. if  $PE = \mathcal{D}_e$  or  $PE = \mathcal{D}_f$ , the two diagrams represent the two possible causality modes (integral and derivative) of the dynamic element: the *integral causality model* is physically realizable, useful in simulation and is the preferred dynamic model in the POG technique. The other *derivative causality model* is still a correct mathematical model of the PE, but it is not used in the POG technique because it is not physically realizable and it is not useful in simulation.

**Power sections in series and in parallel:** each Physical Element (PE) interacts with the external world through the

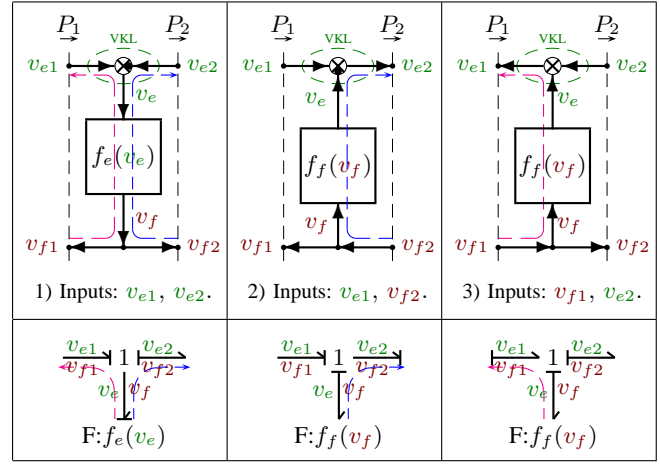

Figure 7. POG and BG graphical representations of a physical element PE with its power sections connected *in series*, see Fig. 6.a.

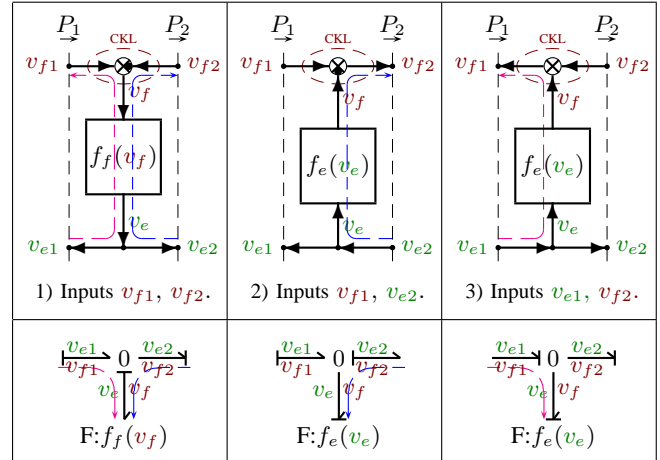

Figure 8. POG and BG graphical representations of a physical element PE with its power sections connected *in parallel*, see Fig. 6.b.

power sections associated to its terminals. The two basic power connections of the physical element PE with the external world are shown in Fig. 6: a) the connection *in series* when the two terminals share the same through-variable  $v_f = v_{f1} = v_{f2}$ ; b) the connection *in parallel* when the two terminals share the same across-variable  $v_e = v_{e1} = v_{e2}$ . Three different POG and BG graphical representations of a PE connected *in series* are shown in Fig. 7. The following considerations hold:

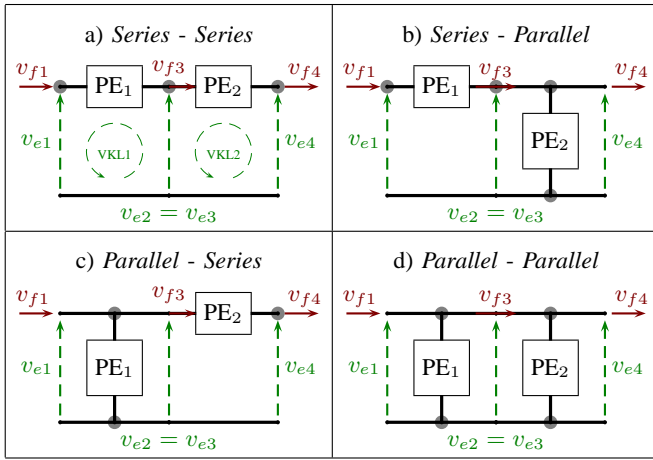

Figure 9. Four types of connections of two physical elements PE<sub>1</sub> and PE<sub>2</sub>.

1) All these graphical representations exactly describe the mathematical model of the PE, but they have different model orientation, i.e. different choices of the input and output variables. In particular, the POG diagrams can be obtained one from the other inverting one of the input-output path. The second POG diagram in Fig. 7, for example, is obtained from the first one inverting the path that goes from  $v_{e2}$  to  $v_{f2}$  as shown by the dashed blue lines. The third POG diagram is obtained from the first one inverting the path that goes from  $v_{e1}$  to  $v_{f1}$  as shown by the dashed red lines. The first POG diagram in Fig. 7 is the basic element for POG modeling all the physical elements and is called the POG *elaboration block*.

2) The summation elements which are present in the POG block diagrams of Fig. 7 are a mathematical description of the Voltage Kirchhoff's Law (VKL) applied to the *across variables*  $v_{e1}$ ,  $v_{e2}$  and  $v_e$  involved in the *closed path* which is always present when the PE is connected in series, i.e. the green closed dashed path shown in Fig. 6.a.

3) In Fig. 7 there is a perfect correspondence between the POG and the BG graphical representations: the BG “half-arrow” corresponds to POG power arrow “→”; the BG “stroke” corresponds to POG “model orientation”; the BG “1-series” symbol corresponds in POG to the fact that all the power sections share the same through-variable  $v_f$  and the adder involves only the across-variables.

4) Note that in the POG graphical representations of Fig. 7 the *across variables* are drawn in the upper side of the figure, while the *through variables* are drawn in the lower side of the figure. This is NOT a general rule for the POG graphical representations. In fact, a POG block diagram can always be rewritten upside-down or left-right switched without losing its meaning and its graphical interpretation.

Similar considerations can also be done for a physical element PE connected *in parallel*, see Fig. 6.b. In this case the three different POG and BG graphical representations of the mathematical model of the PE are shown in Fig. 8. In this figure the BG “0-parallel” symbol corresponds to the fact

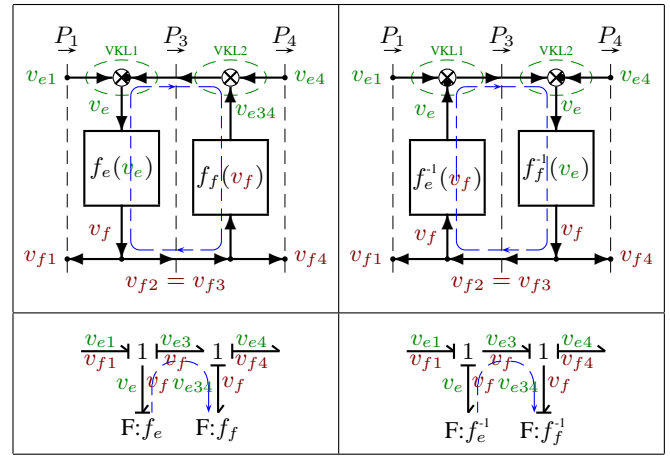

Figure 10. Two POG models (and two BG models) corresponding to the “a) Series - Series” connection shown in Fig. 9

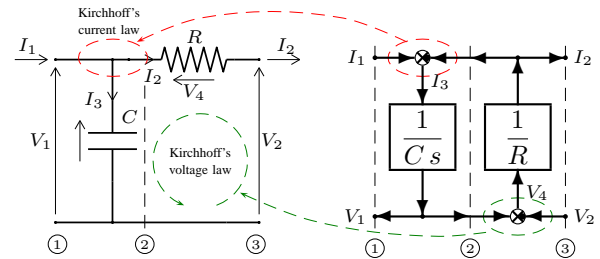

Figure 11. POG modeling of an electrical RC circuit.

that in POG all the power sections share the same across-variable  $v_e$  and the adder involves only the through-variables. Moreover, in this case, the summation elements present in the POG block diagrams of Fig. 8 are a mathematical description of the Current Kirchhoff's Law (CKL) applied to the *through variables*  $v_{f1}$ ,  $v_{f2}$  and  $v_f$  involved in the “node” corresponding to terminal 1 of the PE connected in parallel, see the red closed dashed line shown in Fig. 6.b.

**Power connections of two physical elements:** two physical elements PE<sub>1</sub> and PE<sub>2</sub> can be connected only through their terminals, i.e. through “the power sections” associated to the terminals. The four possible ways of connecting two physical elements PE<sub>1</sub> and PE<sub>2</sub> are shown in Fig. 9. When two power sections are connected, a *feedback loop* always arises in the POG graphical representation of the system. In Fig. 10 it is shown, for example, two different POG mathematical models (and two BG models) that can be associated to the “a) Series - Series” connection shown in Fig. 9. Note that the second POG model can be obtained from the first one by inverting the closed loop path (i.e. the dashed blue line) present in the first POG model. One model can be preferred respect to the other depending on the causality orientations desired for the two physical elements PE<sub>1</sub> and PE<sub>2</sub>. Also in this case it is evident the perfect correspondence between the POG and the BG models: the POG *inversion of the internal path* corresponds to the BG *stroke inversion* of the path which goes from  $f_e$  to  $f_f$ . A simple example of POG modeling is shown in Fig. 11 where

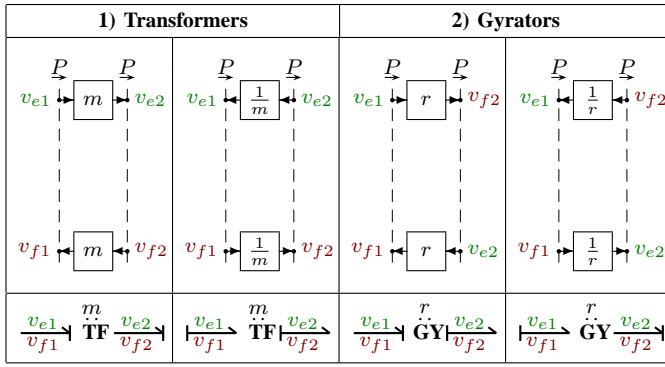

Figure 12. POG and BG graphical symbols used for the *Connection blocks*.

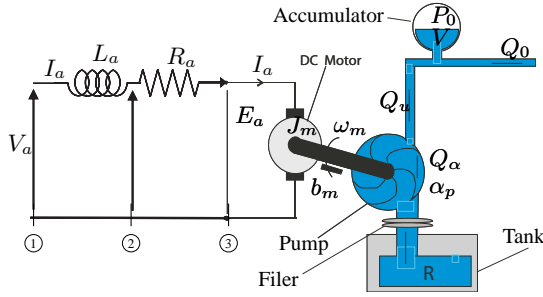

Figure 13. A DC motor connected with an hydraulic pump.

a C-parallel element is connected with an R-series element: this is a particular case of the “(c) *Parallel - Series*” connection shown in Fig. 9. Note the direct correspondence between the power sections ①, ②, ③ in the system and the dashed power sections ①, ②, ③ in the POG scheme.

**Connection blocks:** the physical elements can also be connected using real physical elements which redistributes the power without storing nor dissipating energy (i.e. any type of gear reduction, mechanical levers, electrical transformers, etc.). The BG technique divide these *neutral elements* into two categories: the *transformers* which link the power variables of the same type (i.e.  $v_{e2} = m v_{e1}$ ,  $v_{f1} = m v_{f2}$ ) and the *gytrators* which link power variables of different types (i.e.  $v_{f2} = r v_{e1}$ ,  $v_{f1} = r v_{e2}$ ). The basic property satisfied by the *neutral elements* is  $P_1 = v_{e1} v_{f1} = v_{e2} v_{f2} = P_2$ , i.e. the input power flow  $P_1$  is always equal to the output power flow  $P_2$ . The POG and BG graphical representations of the basic *neutral elements* are shown in Fig. 12. From the figure it is evident that the POG technique uses only one type of block (i.e. the **connection block**) for representing all the possible types of *neutral elements* that can be found in real world.

**Example of POG modeling:** a DC motor connected with an hydraulic pump is shown in Fig. 13. This system involves three different energetic domains: electrical, mechanical and hydraulic. The corresponding POG graphical representation in shown in Fig. 14: the power sections present in the POG scheme have a direct correspondence with the real physical sections. Let  $\mathbf{x} = [I_a \ \omega_m \ V_0]^T$  be the state vector of the system, i.e. the output variables of the dynamic elements. From the POG scheme one directly obtains the following state space

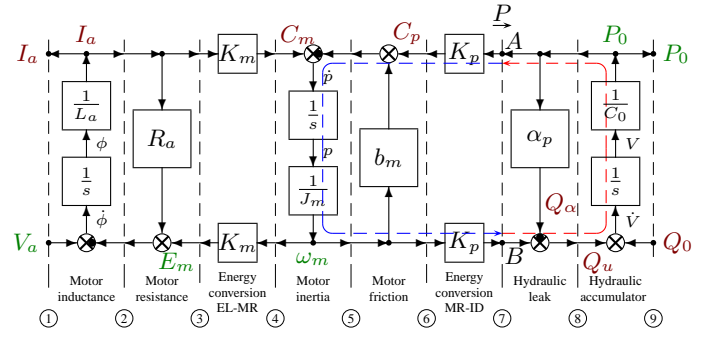

Figure 14. POG scheme of the DC motor with hydraulic pump of Fig. 13.

dynamic model  $\mathbf{L}\dot{\mathbf{x}} = -\mathbf{A}\mathbf{x} + \mathbf{B}\mathbf{u}$ :

$$\underbrace{\begin{bmatrix} L_a & 0 & 0 \\ 0 & J_m & 0 \\ 0 & 0 & C_0 \end{bmatrix}}_{\mathbf{L}} \underbrace{\begin{bmatrix} \dot{I}_a \\ \dot{\omega}_m \\ \dot{P}_0 \end{bmatrix}}_{\dot{\mathbf{x}}} = \underbrace{\begin{bmatrix} -R_a & -K_m & 0 \\ K_m & -b_m & -K_p \\ 0 & K_p & -\alpha_p \end{bmatrix}}_{-\mathbf{A}} \underbrace{\begin{bmatrix} I_a \\ \omega_m \\ P_0 \end{bmatrix}}_{\mathbf{x}} + \underbrace{\begin{bmatrix} 1 & 0 \\ 0 & 0 \\ 0 & 1 \end{bmatrix}}_{\mathbf{B}} \underbrace{\begin{bmatrix} V_a \\ Q_0 \end{bmatrix}}_{\mathbf{u}} \quad (1)$$

where  $\mathbf{u}$  is the input vector and  $\mathbf{L}$ ,  $\mathbf{A}$  and  $\mathbf{B}$  are matrices that can be obtained by direct inspection of the POG scheme. In the considered case matrix  $\mathbf{L}$  is diagonal and its elements are the coefficients of the constitutive relations  $\phi = L_a I_a$ ,  $p = J_m \omega_m$ ,  $V = C_0 P_0$  of the dynamic elements of the system. The coefficients of matrices  $-\mathbf{A}$  and  $\mathbf{B}$  are the gains of all the paths that link the state variables  $\mathbf{x}$  and the input variables  $\mathbf{u}$  to the inputs  $\dot{\phi}$ ,  $\dot{\omega}_m$ ,  $\dot{V}$  of the integrators in the system. The element  $a_{2,3}$  of matrix  $-\mathbf{A}$ , for example, is the gain of the path that goes from the third state variable  $P_0$  to the input  $\dot{p}$  of the second integrator. The element  $b_{3,2}$  of matrix  $\mathbf{B}$  is the gain of the path that goes from the second input  $Q_0$  to the input  $\dot{V}$  of the third integrator.

**POG general compact form:** for linear systems, the general state space compact form obtained from a POG scheme is given by eq. (2) in Fig. 15 where  $\mathbf{y}$  is the output vector,  $\mathbf{L}$  is the *energy matrix*,  $\mathbf{A}$  is the *power matrix*,  $\mathbf{B}$  is the *input power matrix*,  $\mathbf{C}$  is the *output power matrix* and  $\mathbf{D}$  is the *input-output power matrix*. The compact state space model can be graphically represented by the compact vectorial POG scheme shown in the left part of Fig. 15. This “compact graphical form” cannot be obtained by using the Bong Graphs technique because  $\mathbf{x}$ ,  $\mathbf{u}$  and  $\mathbf{u}$  are, in the general case, effort-flow mixed vectors. For a POG linear system expressed in the compact form (2) the following properties hold: 1) the energy matrix  $\mathbf{L}$  is symmetric positive definite:  $\mathbf{L} = \mathbf{L}^T > 0$ ; 2) the *energy*  $E_s$  stored in the system can be expressed as:  $E_s = \frac{1}{2} \mathbf{x}^T \mathbf{L} \mathbf{x}$ ; 3) the *dissipating power*  $P_d$  in the system can be expressed as:  $P_d = \mathbf{x}^T \mathbf{A}_s \mathbf{x}$  where  $\mathbf{A}_s = \frac{(\mathbf{A} + \mathbf{A}^T)}{2}$  is the symmetric part of the power matrix  $\mathbf{A}$ ; 4) the skew-symmetric part  $\mathbf{A}_w = \frac{(\mathbf{A} - \mathbf{A}^T)}{2}$  of the power matrix  $\mathbf{A}$  represents the *power redistribution within the system “without losses”*, i.e.  $P_d = \mathbf{x}^T \mathbf{A}_w \mathbf{x} = 0$ .

For system (1) we have that:  $E_s = \frac{1}{2} L_a I_a^2 + \frac{1}{2} J_m \omega_m^2 + \frac{1}{2} C_0 P_0^2$ ,  $P_d = R_a I_a^2 + b_m \omega_m^2 + \alpha_p P_0^2$  and matrix  $\mathbf{A}_w$  is function only of the connection parameters  $K_m$  and  $K_p$ .

**Transformed and reduced POG systems:** a POG system expressed in the compact form (1) can be transformed into

